

# Exclusive Cantilever Gates



**ZIPTRACK™**  
ALUMINUM CANTILEVER GATES

**ELITE FENCE PRODUCTS, INC.**

# ZipTrack™ Chainlink Gates



All Gates  
Feature  
Enclosed  
Lower Guide  
Wheels

*Dual Track Frame Only Plus Barb*



*Frame Only Plus Barb*



*Frame Only w/Optional Slats Installed*



*Frame Only Plus Barb*



- GATES AVAILABLE TO SECURE ANY OPENING
- TUBULAR DIAGONAL BRACING, NO TRUSS RODS OR CABLES TO BREAK OR ADJUST
- LOWER FRAME WITH TOTALLY ENCLOSED GUIDE WHEEL, ELIMINATES THE PINCH POINT AND HELPS REDUCE LATERAL MOVEMENT.

[WWW.ELITEFENCE.COM](http://WWW.ELITEFENCE.COM)

VISIT OUR WEBSITE FOR  
MORE IMAGES AND INFORMATION

PROUDLY MADE IN AMERICA  
EXTRUDED & ASSEMBLED



# ZipTrack™ Aluminum Cantilever Gates

## ZipTrack™ Single Track

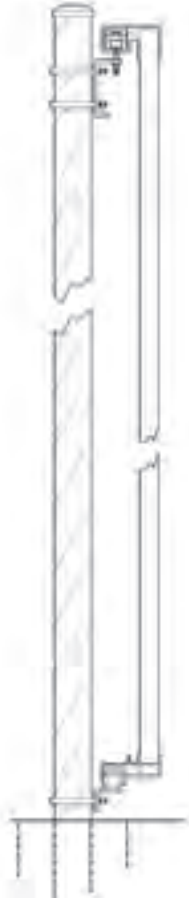

## ZipTrack™ Dual Track

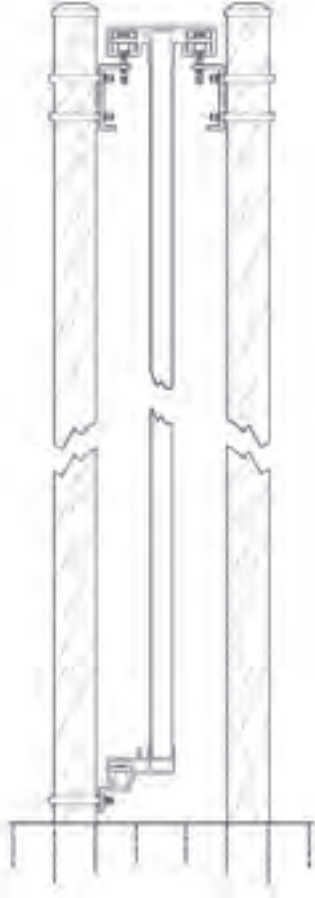

## ZipTrack™ Box Frame

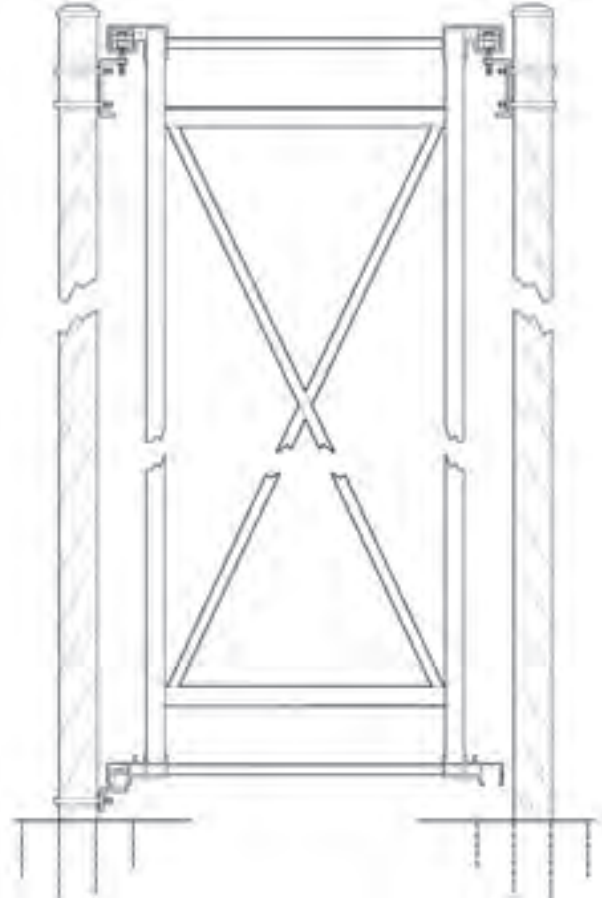

	Single Gate Opening	Double Drive Opening
ZipTrack™ Single Track	4'-30'	8'-60'
ZipTrack™ Dual Track	31'-40' **	62'-80' **
ZipTrack™ Box Frame	41'-60' **	82'-120' **

	Heights	Colors
ZipTrack™ Ornamental Gates	3' High-10' High	Black, White, Quaker Bronze, Hartford Green, Walnut Brown, Beige, Sandstone *
ZipTrack™ Frame Only	4' High-12' High	Mill Finish, Black, Chainlink Brown, Chainlink Green *
ZipTrack™ Frame Only Plus Barb	6'+1' High-12'+1' High	Mill Finish, Black, Chainlink Brown, Chainlink Green *

\*Custom Colors available and quoted per request

\*\*Some assembly may be required

-Super durable polyester powder coated finish.  
In certified testing, this finish has been proven to meet or exceed AAMA 2604-05 specifications.



# ZipTrack™ Components & Hardware

## ZipTrack™ Upper Track

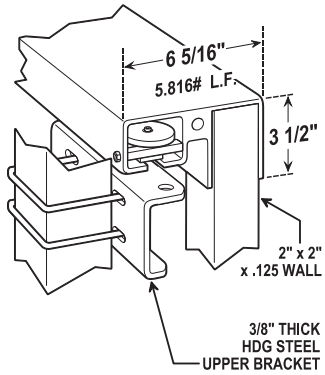

## ZipTrack™ Dual Track

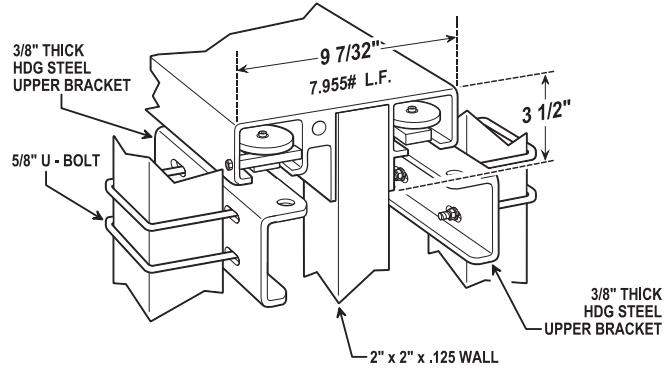

## ZipTrack™ Lower Track

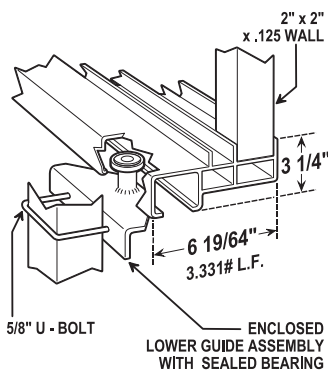

## ZipTrack™ Z4 Truck Assembly

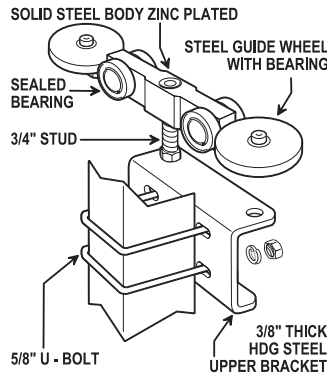

## ZipTrack™ Z8 Truck Assembly

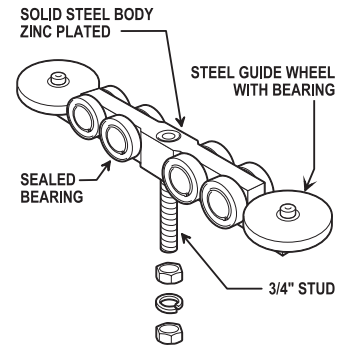

## ZipTrack™ One & Two Piece Receiver

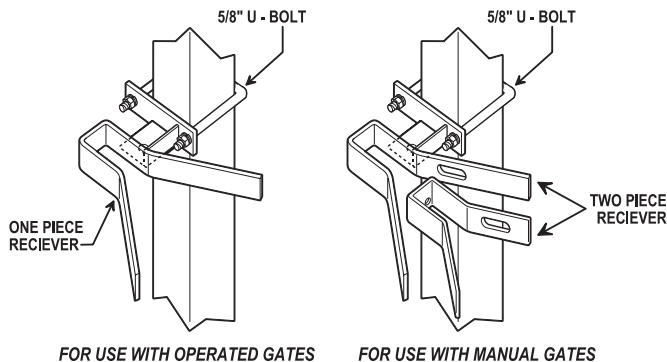

Manufactured by:

Elite Fence Products, Inc.  
25551 Joy Blvd.  
Harrison Twp., MI 48045  
Phone (586) 468-4448  
Toll-Free 1-800-783-1331  
Fax (586) 468-4884

[www.elitefence.com](http://www.elitefence.com)

# ZipTrack™ Ornamental Gates



*EFS-10 w/Optional 2-Rail Estate Top*



*EFS-66*



*EFF-20*



*EFS-50*

Elite Fence Products was established in 1986 and is family owned and operated. Elite manufactures aluminum fencing, railing and gate products utilizing only the highest quality materials available. The management and sales staff is comprised of individuals who are highly experienced in all aspects of the fence installation and manufacturing industry. All products are manufactured and powder coated in our state-of-the-art facility located in Harrison Township, Michigan.





## Specifications – ZipTrack™ Aluminum Cantilever Slide Gate

As manufactured by Elite Fence Products, Inc. shall conform to the following specifications:  
FS RR-191/2D Type III & IV and ASTM F 1184-88.

**FULLY FABRICATED GATE** – The gate shall be fabricated in Elite Fence Product's Plant. The frames and tracks are fabricated from extrusions (6005-T5). The upper track weighs 5.816# per foot and lower 3.331# per foot. The upper and lower tracks shall be welded and/or bolted to 2" x 2" x .125 Wall tubes at 1.106# per foot vertical framing. Each section for the tail shall be X-braced with two (2) 2" x 2" x .125 Wall tubes at 1.106# per foot. Each front section shall have one (1) 1" x 2" tube at .824# per foot diagonal brace for ornamental gates, and (1) 2" x 2" x .125 Wall tube at 1.106# per foot diagonal brace for chainlink gates. Gates made for chainlink may be shipped with the wire in place or the wire can be installed at the job site. The fabric shall be held in place by tension bars, tension bands and bolts. Barbwire shall be held in place by brace bands and bolts.

**ORNAMENTAL PICKET TYPE GATES** – The upper track will have holes punched to accepted 1" x 1" x .062 wall picket, the pickets shall be attached by using 410 stainless steel screws. The heads are coated with zinc and yellow chromate, and then painted to match the color of the gate. All gates are manufactured with no picket through bottom to meet UL 325.

**KNOCKED DOWN GATE** – A knocked-down gate can be supplied ready to assemble. All hardware is furnished and all necessary holes are pre-drilled.

**TRUCK ASSEMBLY** – Two (2) swivel type truck assemblies consisting of a solid steel zinc plated body, utilizing a 3/4" mounting stud. Each having two (2) axles press fitted to the main body. The axles are then press fitted with four (4) permanently lubricated sealed ball bearing wheels mounted vertically for rolling the gate. Two (2) top mounted steel horizontal rolling wheels with sealed bearings are used for alignment.

**LOWER GUIDES** – Two permanently lubricated sealed ball bearing wheels are mounted to the gate post and should be vertically centered in the lower track. All brackets and gate latches shall be galvanized after fabrication.

*ZipTrack™ Aluminum Cantilever Gates and Truck Assemblies  
are covered under a Five Year Limited Warranty.*

*Manufactured by:*

**Elite Fence Products, Inc.**  
**25551 Joy Blvd.**  
**Harrison Twp., MI 48045**  
**Phone (586) 468-4448**  
**Toll-Free 1-800-783-1331**  
**Fax (586) 468-4884**

**www.elitefence.com**



PROUDLY MADE IN AMERICA  
EXTRUDED & ASSEMBLED



*Distributed by:*